

Advanced Wind Technology: New Challenges for a New Century

Conference Paper
NREL/CP-500-39537
June 2006

R. Thresher and A. Laxson

*Presented at the European Wind Energy Conference
Athens, Greece
February 27–March 2, 2006*



NREL is operated by Midwest Research Institute • Battelle Contract No. DE-AC36-99-GO10337



NOTICE

The submitted manuscript has been offered by an employee of the Midwest Research Institute (MRI), a contractor of the US Government under Contract No. DE-AC36-99GO10337. Accordingly, the US Government and MRI retain a nonexclusive royalty-free license to publish or reproduce the published form of this contribution, or allow others to do so, for US Government purposes.

This report was prepared as an account of work sponsored by an agency of the United States government. Neither the United States government nor any agency thereof, nor any of their employees, makes any warranty, express or implied, or assumes any legal liability or responsibility for the accuracy, completeness, or usefulness of any information, apparatus, product, or process disclosed, or represents that its use would not infringe privately owned rights. Reference herein to any specific commercial product, process, or service by trade name, trademark, manufacturer, or otherwise does not necessarily constitute or imply its endorsement, recommendation, or favoring by the United States government or any agency thereof. The views and opinions of authors expressed herein do not necessarily state or reflect those of the United States government or any agency thereof.

Available electronically at <http://www.osti.gov/bridge>

Available for a processing fee to U.S. Department of Energy and its contractors, in paper, from:

U.S. Department of Energy
Office of Scientific and Technical Information
P.O. Box 62
Oak Ridge, TN 37831-0062
phone: 865.576.8401
fax: 865.576.5728
email: <mailto:reports@adonis.osti.gov>

Available for sale to the public, in paper, from:

U.S. Department of Commerce
National Technical Information Service
5285 Port Royal Road
Springfield, VA 22161
phone: 800.553.6847
fax: 703.605.6900
email: orders@ntis.fedworld.gov
online ordering: <http://www.ntis.gov/ordering.htm>



Advanced Wind Technology New Challenges for a New Century

Robert Thresher, Alan Laxson,* National Renewable Energy Laboratory,
1617 Cole Blvd, Golden, CO, 80401-3393, USA

Summary

Wind Energy demonstrated phenomenal growth and improvement in the later three decades of the 20th century. From small niche markets for pumping water and charging batteries, wind became an important supplier of grid tied electricity. These improvements saw modern commercial wind electrical generators grow from simple 50-kilowatt (kW) units to sophisticated multimegawatt (MW) machines capable of generating millions of kilowatt-hours (kWh) per year. The technical advances in wind energy in this time frame were not revolutionary. Scaling to larger size was the primary approach used to improve the cost effectiveness; and improved design methods to properly size turbines for their operating wind environment. Advances in generators, gearboxes, blade designs, blade materials, controls, and computers using improved design codes allowed machines to improve in performance and grow in size until the average modern wind turbine is now more than 1 MW in rating. But as with any maturing technology, most of the easier improvements have already been implemented.

Now, at the beginning of the 21st century, wind energy is facing a new set of technical challenges to achieve cost effectiveness in the lower wind speed regimes located closer to large load centers, while avoiding transmission congestion points as much as possible. Success in lower wind regimes and mature turbine design methodologies will require that more technically challenging innovative designs be explored. The application of taller towers to take advantage of higher winds aloft to increase energy capture at the lower wind speed sites is necessitating new research into the turbulent environments at levels of 80 to 150 meter above the ground. At this elevation, the atmospheric boundary layer is much different than near the ground, and new simulation models are needed for this so called mixing layer above Great Plains sites. In addition, new turbine designs of much greater size are being considered for offshore deployment in shallow and even deep waters in both the United States and Europe, where the offshore design environment is quite different than for land-based turbines.

Anticipated improvements in technology that will be seen in the next decade in response to these new challenges include: custom designed permanent-magnet (PM) generators; variable-speed power electronic power converters with improved performance characteristics and reliability; unique gearbox designs that are smaller and lighter; improved aerodynamic and structural dynamics codes that accurately predict unsteady loads and aerodynamic stall effects for lighter more flexible turbines under wide ranging atmospheric conditions; improved rotors that utilize aeroelastically tailored blades of advanced materials such as carbon-epoxy composites; advanced controls techniques that can decrease total machine loads without increasing machine cost; higher blade tip speeds with reduced blade chord and lower aeroacoustic emissions; novel new towers employing self erection or advanced composite materials; offshore machines supported on floating platforms; and improved marine electrical collection systems. Any one of these improvements would be considered a major technological advance, but the wind turbine of 2015 will need many, if not all of these innovations to become the low-cost electricity generator of the future.

A Long Road Traveled

Until the early 1970s, wind energy filled a small niche market, providing mechanical power for grinding grain and pumping water. With the exception of a small number of battery chargers and the rare experiments with larger electricity producing machines, the windmill of 1850, or even 1950, differed little from the device of 1200 AD, but the later half of the 20th century saw spectacular changes in the technology. Drag-based devices and simple lift-based designs gave way to experimentally designed and tested high-lift rotors, many with full span pitch control. Blades that had once been made of sail or sheet metal progressed through wood to advanced fiberglass composites with added carbon fibers for stiffness and strength. The DC alternator gave way to the induction generator that was grid synchronized, which is giving way to variable-speed designs dependent upon the high-speed switches of advanced power electronics. From simple inertial controls that feathered or furled a machine, designs moved to high-speed digital controls. A 50 kW machine, considered large in 1970, is now dwarfed by the 1.5 to 3.6 MW machines being

* Employees of the Midwest Research Institute under Contract No. DE-AC36-99GO10337 with the U.S. Dept. of Energy have authored this work. The United States Government retains, and the publisher, by accepting the article for publication, acknowledges that the United States Government retains a non-exclusive, paid-up, irrevocable, worldwide license to publish or reproduce the published form of this work, or allow others to do so, for the United States Government purposes.

actively marketed and installed today. Many advances in design technology have contributed to these changes. Airfoils are tested in wind tunnels and are designed for insensitivity to surface roughness and dirt. Our knowledge of aero induced loads and the ability to incorporate this knowledge into finite element models and structural dynamics codes make the machine of today more robust but lighter on a relative basis than those of a decade ago. However, as with any maturing technology, many of the simple improvements have been tapped out.

Challenges for a Maturing Technology

At the beginning of the 21st century, wind energy is facing a new set of challenges. Many of the most desirable high wind speed sites have been developed, and those sites that are still available face severe difficulty gaining access to declining transmission capacity. To continue its phenomenal growth, wind turbine designs must evolve to make lower wind speed sites more attractive. It has been shown that Class 4 sites with wind speeds of 7.25 m/s represent almost 20 times the developable wind resource as Class 5 and 6 sites with wind speeds of 7.5 to 8.8 m/s. Class 4 sites on average are also much closer to many loads centers, averaging 100 miles versus 500 miles for Class 6 sites. Making wind energy more cost effective in the Class 4 sites will drastically improve wind's future opportunities. To accomplish this and continue wind energy growth, machine designs must overcome a number of barriers.

Machine growth – Over the past 20 years, average wind turbine ratings have grown almost linearly (Figure 1), with current commercial machines rated at 1.5 MWs. Each group of wind turbine designers has predicted that the machines of today are as large as they will ever be. However, each new generation of wind turbines (roughly every five years) has grown along the linear curve and has achieved reductions in life cycle cost of energy. The primary argument for limits in size is based on the “square-cube law.” Roughly stated this says “as a wind turbine rotor goes up in size, its power increases as the square of the rotor, while its mass increases as the cube.” Engineers have successfully overcome this barrier by innovation in design and materials. Studies have shown that in recent years, blade mass has been scaling at roughly an exponent of 2.5 versus the expected 3 [1].

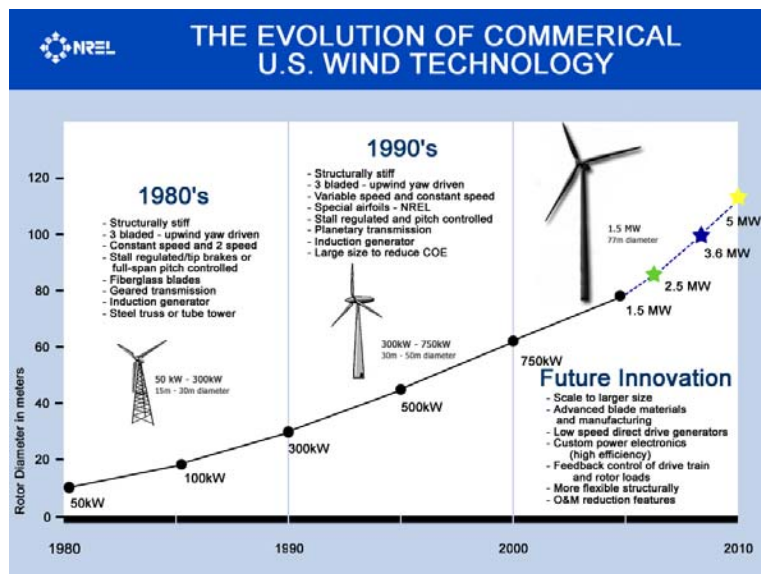

Figure 1. Wind turbine growth.

The desire to increase the size of machines is also driven by the deployment of wind in off-shore environments. The cost of installing marine foundations, being significantly larger than onshore, demands that the maximum energy capture be achieved from each foundation, thus leading to larger rotor diameters. But how long can such improvements continue and not reach a ceiling of size and mass?

Land transportation represents yet another potential limiting factor for wind turbine growth. Cost-effective transportation can be achieved by remaining within standard over-the-road trailer dimensions of 4.1 m high by 2.6 m wide. Weights should remain under 80,000 lbs GVW corresponding to a cargo weight of about 42,000 lbs. Loads that exceed 4.83 m in height will trigger expensive utility and police assistance. These dimension limits have the most impact on the base diameter of wind turbine towers. Rail transportation is even more dimensionally limited. Overall widths should remain within 3.4 m while heights are limited to 4.0 m. Limitations are driven by tunnel and overpass widths and heights. Transportation weights are less of an issue in rail transportation with GVW of 360,000 lbs possible [2].

Erection– Increases in machine size have several effects on turbine erection. Larger rotor diameters and the desire to take advantage of wind shear by increasing tower heights to place rotors in higher velocity winds are all driving hub heights higher. Average turbine hub heights are now 65 meters, but a 2.5 to 3.5 MW turbine on the Great Plains will demand a hub height of 80 to 100 meters with hub heights increasing for larger machines. Also, as hub masses and tower heights increase, tower diameters must increase, as well as tower thickness to withstand increased bending and buckling loads. Both effects can increase erection costs. But, assuming a tower can be segmented and erected in sections, the nacelle mass appears to be the limiting factor in turbine erection. Projected masses for nacelles in the 2.5

to 3.5 MW range run from 295,000 to 430,000 lbs. Lifting this mass requires a crane with a much greater lifting capacity than expected because of the extreme nacelle height. (It must be remembered that crane ratings are based on lifts with little or no boom extension. As the boom is extended both up and out, the lift rating decreases.) Crane costs for placing a 2.5 MW turbine on a 110 m tower are expected to run \$40,000 to \$50,000. While crane costs for erecting a 5 MW turbine on a 156 m tower would run as high as \$138,000. Reductions in tower height and in turbine tower head mass would significantly reduce these costs. These masses and costs are based on machine scaling projections and spreading the mobilization and demobilization costs over a 50 MW wind farm. Other limiting factors are that cranes with this lifting capacity are rare, are difficult to transport, require large crews, and they have very large mobilization and de-mobilization costs. In addition, moving cranes between turbine erection sites is also extremely costly and time consuming [2].

The Low Level Jet –

Another factor that will effect the design of turbines of the future, particularly on the Great Plains, is the low level (or nocturnal) jet. The nocturnal jet is a poorly understood phenomenon that occurs at nighttime as cooling allows the winds to stabilize into parallel layers flowing at different velocities.

Kelvin-Helmholtz (K-H) instabilities can form at the boundaries between these parallel layers (Figure 2). These instabilities can rapidly grow into large-scale coherent vortices that can reach the ground and cause gust loads on turbine rotors. While the nocturnal jet can occur anywhere, it is most prevalent over areas of the Great Plains; regions that represent some of the best Class 4 wind resources. While the low level jet will not limit wind growth, it is clear that wind turbine designers must clearly understand the implications of the extreme coherent gusts as they place ever larger rotors on taller towers.

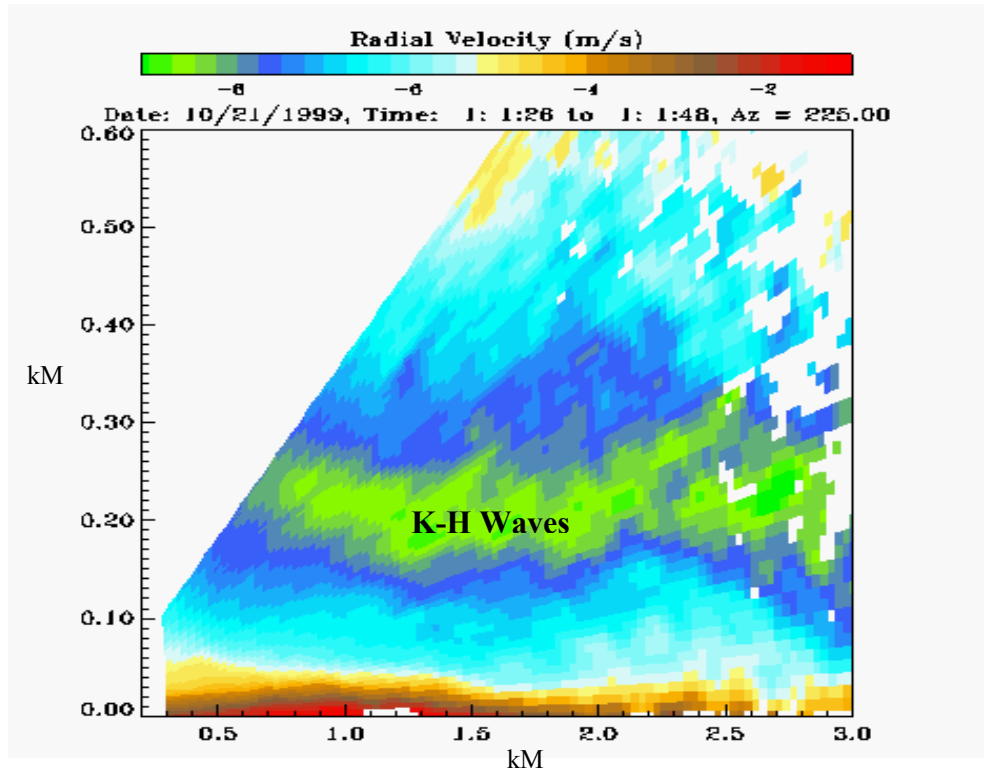

Figure 2. Kelvin-Helmholtz (K-H) instabilities can form at the boundaries between these parallel layers

Grid Interconnection – Concerns exist that the intermittent nature of wind power could adversely affect grid stability limiting wind penetration. Wind turbines do not follow a predictable pattern of power generation, except in rare locations driven strongly by local weather patterns and land forms, such as in some of the passes of California. The requirements of power plant operators deal with three different time scales: regulation – being seconds to minutes; load following – being tens of minutes to hours; and, scheduling – being daily (Figure 3). The timing associated with wind power generation has been difficult to predict until recently. The fear that the output of large wind power plants will plummet to zero in a matter of minutes or seconds has hampered a number of major developments. But recent research is shedding a brighter light on the ability of wind power plants to provide a more grid friendly connection.

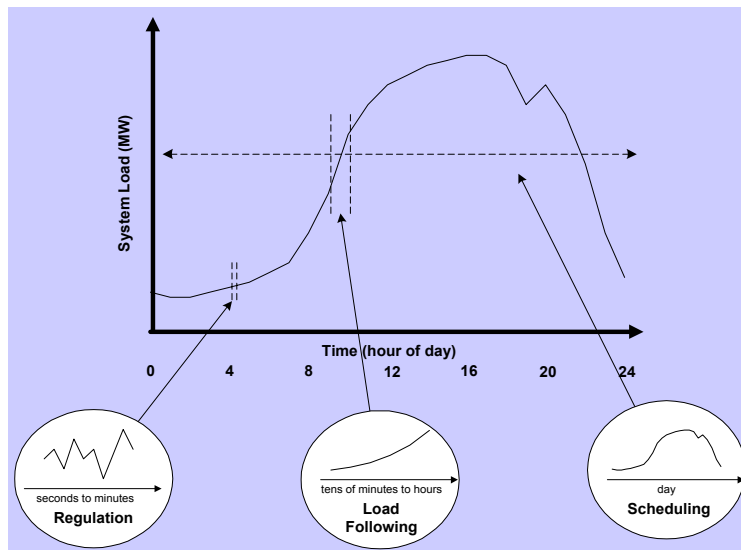

Figure 3. The requirements of power plant operators deal with three different time scales: regulation – being seconds to minutes; load following – being tens of minutes to hours; and, scheduling – being daily.

Offshore – Recent years have seen a boom in offshore deployments in the Baltic and North Seas. Although these developments have been primarily driven by the dearth of new onshore development sites, significant wind resources have been identified in offshore regions of both Europe and the Americas. While the marine environments would seem similar, it is believed that weather extremes along the northern Atlantic coast may present additional challenges for developers. An improved understanding of wind and wave loading and bottom conditions in these novel environments will be critical for future development. The challenging marine environment will also make routine access to machines less than routine.

Technologies for Future Success

The myriad of challenges facing wind turbine designers will demand a wide range of technical responses. Innovation in design approaches, materials, machine configuration, operational parameters, controls, and power conversion techniques will all have to be explored to achieve the projected future cost reductions. Many concepts are already on the drawing board or under development.

Wind Turbine Rotors – The conversion of aerodynamic power to mechanical torque is perhaps the most unique aspect of wind turbine operation. The ability to withstand changing aerodynamic loads and effectively extract power from the wind over a 20-year lifespan makes wind turbines cost effective. As machines grow larger and larger, rotors must increase accordingly. A 1.5 MW turbine has a rotor of approximately 70 meters in diameter. A 3 MW rotor is roughly 99 meters in diameter. While the blade length only increases by 41%, the blade root flap bending moment can increase by levels approaching 160%, depending upon design [3]. These load increases demand significant innovation in design. Several approaches have already been developed or are being tested to help either alleviate these load levels or create load resistant designs. Carbon fibers have been incorporated into wind turbine blades for some years to provide localized strength. But the future will see lighter stiffer blades incorporating large volumes of carbon fabrics presenting options for both tolerating higher blade loads as well as reducing overall machine loads by reducing rotor weight. Blade planforms are being developed that incorporate unique inboard airfoils using truncate airfoil shapes (Figure 4). These planforms provide increased thickness to chord ratios, providing a greater structural cross section to react to outboard loads.

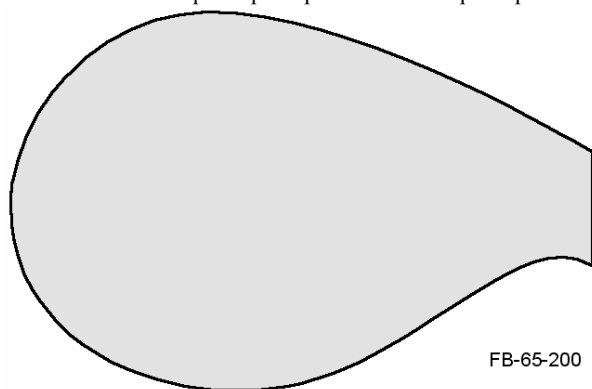

Figure 4. Blade planforms are being developed that incorporate unique inboard airfoils using truncate airfoil shapes

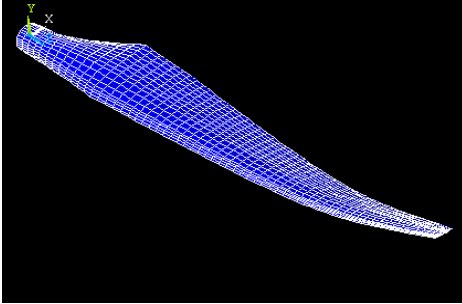

Figure 5. Flap-pitch, also called bend-twist, coupling allows the outer portion of the blade to twist as it bends.

Active designs that can reduce loads are also being explored. The concept of aeroelastic coupling, the change in shape of the blade as it bends under load, offers possibilities for loads alleviation. Flap-pitch, also called bend-twist, coupling allows the outer portion of the blade to twist as it bends (Figure 5). This is accomplished by designing the internal structure of the blade, or orienting the fiberglass and carbon plies within the layups, in such a way as to make the blade flex in pitch as it bends. This twisting therefore changes the angle of attack over much of the blade. If properly designed, this change in angle of attack will reduce the lift and therefore reduce loads. Such designs offer a method of almost instantaneously tailoring blade profiles to alleviate loads without placing additional demands upon blade pitch systems. The designs must be developed, tested, and optimized so as not to adversely impact energy production.

Concepts such as on-site manufacturing and segmented blades are also being explored to help reduce transportation costs. It may be possible to segment plan molds and move them into temporary buildings close to the site of a major wind installation so that the blades can be made close to the site and transported only a few miles.

Novel Drivetrains: Converting torque to electrical power has historically been achieved using a speed increasing gearbox and an induction generator. Many current megawatt-scale machines depend on a three-stage gearbox consisting of varying arrangements of planetary and parallel shaft gearing. Generators are either squirrel cage induction or wound-rotor induction, with some newer machines using the doubly-fed induction design for variable speed. But as machines continue to grow in size, additional stages and ever larger gearboxes are required.

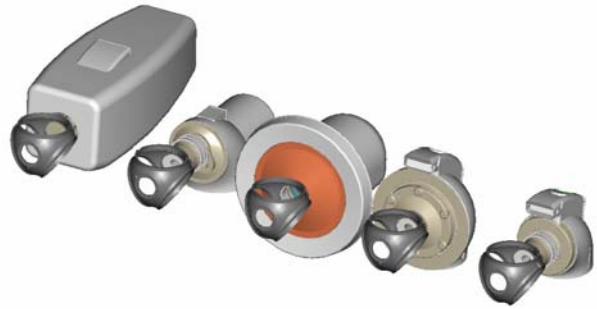

Figure 6. Unique drivetrain designs under development to reduce size and cost.

Several unique designs are under development to reduce the impact of this growth (Figure 6). By 2000, Enercon had developed a megawatt-scale direct-drive generator with a wound-rotor salient pole design with 80 magnetic poles. However, wound-rotor direct-drive generators for growing megawatt-scale machines are 10 meters and more in diameter, making their transport over land problematical unless techniques such as segmented rotor designs are employed. The decrease in cost and increase in availability of rare earth permanent magnets is expected to significantly effect the cost of future generator designs.

Neodymium-Iron-Boron, the permanent magnet (PM) material of choice, has a density close to steel with a magnetic flux density close to that of an electromagnet. However, this magnetic flux density is achieved without the additional mass, size, and cost of the copper windings required for an electromagnet. This allows the creation of smaller generators. A preliminary design for a 1.5 MW direct-drive generator using rare earth PMs has been studied under the WindPACT project at the U.S. Department of Energy's National Renewable Energy Laboratory (NREL). This design uses 56 poles and is only 4 meters (m) in diameter, versus the 10 m for

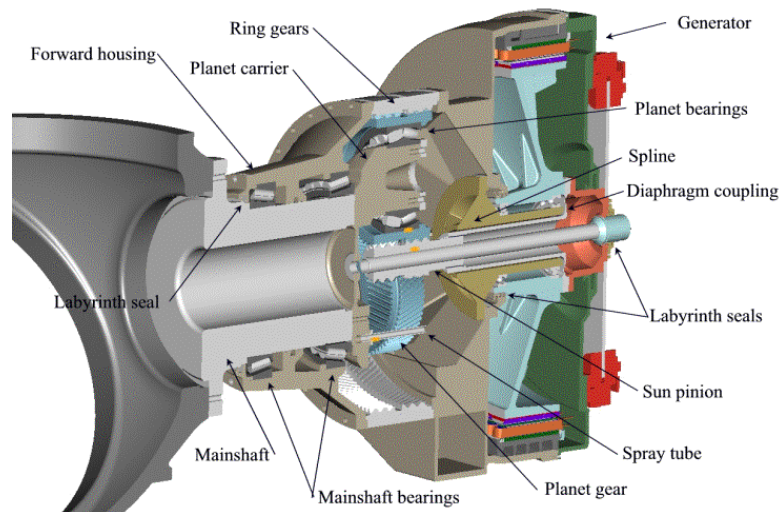

Figure 7. Single-stage drivetrain uses low-speed generator.

a wound rotor design [4]. This machine has been built and is undergoing testing at the National Wind Technology Center.

A hybrid of the direct-drive approach that offers promise for future large-scale designs is the single-stage drive using a low-speed generator (Figure 7). The single-stage drive consists of a single-stage gearbox with a speed increase range from 6 to 1 to as high as 10 to 1. This allows the use of a low-speed generator that is significantly smaller than a comparable direct-drive design. The WindPACT drivetrain project has developed a prototype for such a drivetrain. This design uses a single-stage planetary drive operating at a gearbox ratio of 9.16:1. This gearbox drives a 190 RPM, 72-pole, PM generator. This approach, which reduces the diameter of the 1.5 MW generator to 2 m, [4] was fabricated and is awaiting testing on the 2 MW dynamometer at NREL's National Wind Technology Center.

Another approach that offers promise for reduced size, weight, and cost is the distributed drivetrain. This concept is based on splitting the drive path from the rotor to drive several parallel generators. Studies have shown that by distributing the rotor torque on the bull gear over a number of parallel secondary pinions, a significant size and weight reduction is achieved. Clipper Windpower developed a 2.5 MW prototype that incorporates this approach in 2005 that was tested at a site near Medicine Bow, Wyoming (Figure 8) and is currently being marketed.



Figure 8. Clipper Wind Power's new 2.5-MW turbine incorporates an innovative distributed drivetrain.

Power Conversion and Conditioning: The growing desire to allow variable-speed operation and produce high quality power is being met by a new generation of power electronics and circuit designs. The advent of medium voltage/high amperage power electronics with high-speed switching rates, such as insulated gate bipolar transistors (IGBTs) has allowed a revolution in the operation of wind turbines. However, wind turbine power converter designs present a unique problem to circuit designers. Because of the profile of wind velocities at most wind sites, wind turbines operate far below their power ratings (30% to 40%) a majority of the time. This means that generators and power converters that are designed for normal industrial applications and achieve their highest performance at rated power are inefficient for wind turbine operation. New designs are being explored that aim to achieve their highest performance at below rated power or have a relatively flat performance curve. Other designs are being explored that employ novel circuit designs to reduce the number of switches, such as matrix converters. Yet other designs will explore the potential advantages of novel switch materials, such as silicon carbide that may allow higher voltages, currents, and operating temperatures in smaller packages.

Another major factor that is beginning to impact design approaches is the need for extremely high reliability for offshore designs. Power converters, computer controls and other power components must be extremely robust or incorporate redundancy to reduce nuisance faults that are much more difficult to deal with on remote offshore installations.

Controls: Advanced control methodologies, as applied to wind turbines, are designed primarily to reduce the cost of energy (COE) in one of two ways: increase energy capture or reduce mechanical loads. To increase energy capture, researchers are exploring a technique called "model referenced adaptive control." This is a control technique in which the controller constantly adapts itself in an attempt to get the real plant (the turbine) to behave like a plant model. In this way, the turbine controller can adapt itself to perform optimally despite rotor variability, blade erosion and site-specific parameters. In an attempt to reduce turbine mechanical loading, a technique called "full-state feedback" with "disturbance accommodating control" (DAC) and periodic control has been implemented. In such a system, many turbine states are fed back through a control loop and a DAC controller with time-varying gains to decide what controls should be activated. A DAC controller has the advantage of allowing disturbances (such as turbulent eddies) to pass through the system while tightly controlling parameters of interest, such as rotor speed and blade loads. Employing time-varying gains that are synchronized to the azimuthal position of each blade allows the advantage of taking in to account turbine parameters that vary during a rotor cycle such as yaw inertia and gravity loads. It is believed that such a system will show significant reduction in turbine rotor, shaft, and tower loads.

Electrical Interconnection – Spatial Variations in Wind.

While it is impossible to absolutely control the availability of wind generated electricity, research and development activities are now rapidly improving our understanding of wind energy's reliability, predictability, and how well it can be integrated into a utility distribution grid. In the past, the fear existed that large wind farms would have their power output drop to zero in a matter of seconds requiring utilities to have spinning reserves on line equal to the wind farm capacity. Studies now show that the large variations in the power output of wind farms occur on the order of hours, fitting well into existing utility procedures for dealing with load following. As Figure 9 shows, while the farm output did drop to zero and rise from zero to full power output, these changes occurred relatively smoothly over 1 to 4 hours, with intermittent peaks and valleys exhibiting much of the same spatial variance. The primary reason for this smoothing effect is the large scale of wind farms (their distribution over a wide geographic area). While the wind gusts and slows at any given turbine, its effects on other turbines in the wind farm vary differently causing the output of the total wind farm to smooth significantly. Figure 9 also shows the output of different wind farms within the same general area but up to 100 miles distant display the same general trends, though time shifted indicating the movements of weather patterns between the different wind farms. These studies performed by NREL are continuing with additional wind farms being instrumented and evaluated to show the overall leveling of variations over more widely dispersed wind farms and wind turbines within the same farm.

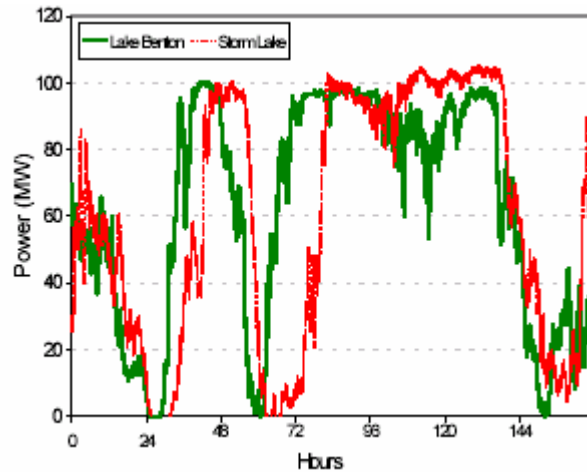

Figure 9. Changes in power output occur over 1 – 4 hours rather than seconds.

Other research is evaluating the ability to forecast wind output in advance based on short-term weather prediction modeling. While such forecasting will not be able to tell a utility operator what the exact wind farm output will be hours or perhaps up to a day in advance, they are expected to reliably indicate available power generation from locally grid connected wind farms within the planning horizon of the utility.

Innovative Towers: The cost impact of extremely large cranes and the transport premiums for large tower sections is driving the exploration of novel tower design approaches. Several concepts are under development or being proposed that would eliminate the need for cranes for very high, heavy lifts. One concept is the telescoping or self erecting tower. This concept allows assembly of the nacelle and rotor at close to ground level and then utilizes hydraulics to jack the tower and nacelle to its operating height. Other self erecting designs are looking at lifting dollies or tower climbing cranes that use tower mounted tracks to lift the nacelle and rotor to the top of the tower. These concepts have the added advantage of being able to bring the nacelle to the ground for major overhauls that would otherwise require expensive cranes.

Construction materials for towers are also under study. A study recently completed for NREL [5], examined the trade-offs for concrete, steel tower hybrids, (Figure 10) looking at the possible cost reductions that may be realized by limiting the size of steel tower sections.

Composites are an additional material under study for wind turbine towers. Small Business Innovation Research projects are exploring several advanced tower concepts using composite materials and novel structures, both of which may lend themselves to onsite manufacturing and ease of transport.

The Ocean Realm: A recent study shows that the United States has the second highest offshore wind resource outside of the European Union [6]. European experience has already demonstrated a range of methods for deploying wind energy in shallow waters (< 30 meters) using driven piers or tripod foundations. To optimize the cost expenditures for these foundations the largest rotor diameters and ratings possible must be considered. GE Windpower has developed a 3.6 MW turbine for offshore deployment, and models of this machine are being installed in European waters. The challenge for the U.S. shallow water environments appears to be a lack of well documented knowledge about the potential wind, wave, and ice loadings in desirable sites. Preliminary studies show that significantly greater resources can be accessed if turbines can be deployed on floating platforms in relatively deep water (up to 200 meters). These installations will challenge designers to develop inexpensive floating or tension leg platforms (Figure 11) with affordable and reliable anchoring systems. Although the United States does not currently have any offshore developments, several projects are in the permitting process.

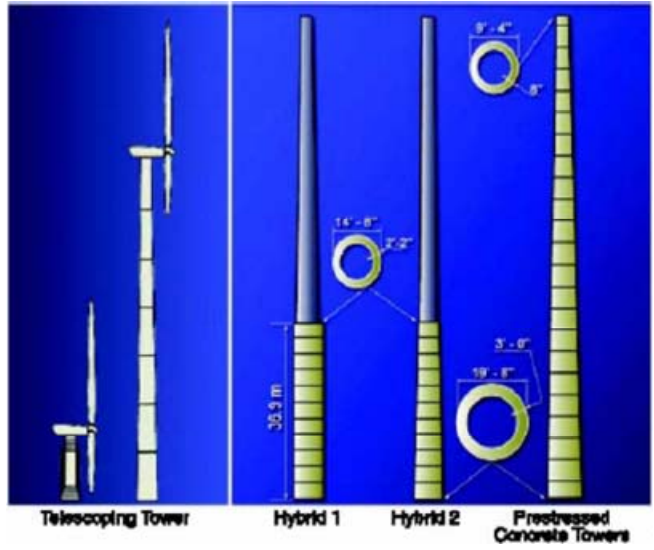

Figure 10. Concrete/steel hybrid towers may reduce construction costs by limiting the steel required for towers.

Additional challenges will face electrical designers who will have to design cost-effective high voltage power collection systems, including offshore substations. However, experience in the offshore oil and gas industry would indicate that the technical challenges can be overcome.

Wind turbines may also change in this unique environment. Some architectural aspects driven by proximity to human habitation will be removed. Aero-acoustics may cease to be a major design driver allowing even higher tip speeds, lower chord, and reduction in loads. The three-bladed upwind machine may eventually give way to the two-bladed downwind, more flexible machine, as more and more machines are deployed afloat and better understanding of the offshore environment is obtained.

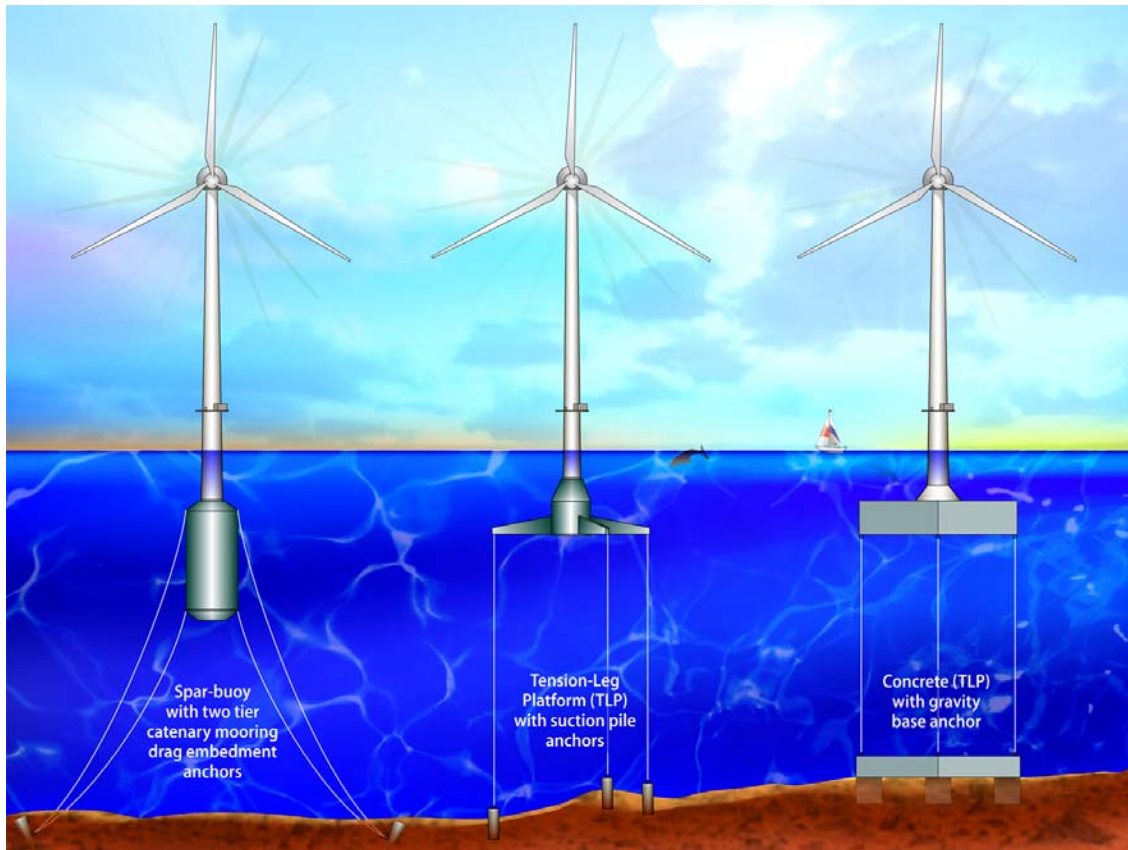

Figure 11. As wind technologies move from onshore to deepwater, new technologies, such as floating platforms, will need to be developed.

Summary

From a distance, the wind turbine of 2015 will not look much different from the large-scale commercial machine of today. The difference in size will be most evident change, with rotor diameters and tower heights dwarfing older machines. But besides the obvious difference in size, machines of the past and machines of 2015 will differ drastically in ways unseen; in the materials of construction, the means of manufacturer, the design of controls and power conversion, advanced smaller and lighter generators, internal blade structure, and many other improvements yet to be quantified. But even upon dissection, the improved techniques, knowledge, and tools used to design these machines will be undetectable except in the lower cost of energy, higher reliability, and reduced cost.

References:

- [1] Griffin, D. A. (2001). WindPACT Turbine Design Scaling Studies Technical Area 1 -- Composite Blades for 80- to 120-Meter Rotor; 21 March 2000 - 15 March 2001. 44 pp.; NREL Report No. SR-500-29492.
- [2] Smith, K. (2001). WindPACT Turbine Design Scaling Studies Technical Area 2: Turbine, Rotor and Blade Logistics; 27 March 2000 - 31 December 2000. 224 pp.; NREL Report No. SR-500-29439.
- [3] Malcolm, D. J.; Hansen, A. C. (2002). WindPACT Turbine Rotor Design Study; June 2000--June 2002. 82 pp.; NREL Report No. SR-500-32495.
- [4] Poore, R.; Lettenmaier, T. (2003). Alternative Design Study Report: WindPACT Advanced Wind Turbine Drive Train Designs Study; November 1, 2000 -- February 28, 2002. 556 pp.; NREL Report No. SR-500-33196.
- [5] LaNier, M. W. (2005). LWST Phase I Project Conceptual Design Study: Evaluation of Design and Construction Approaches for Economical Hybrid Steel/Concrete Wind Turbine Towers; June 28, 2002 -- July 31, 2004. 698 pp.; NREL Report No. SR-500-36777.
- [6] Siegfriedsen, S; Lehnhoff, M; Prehn, A; "Offshore Wind Energy Potential outside the European Union" aerodyn Engineering GmbH.

REPORT DOCUMENTATION PAGE

Form Approved
OMB No. 0704-0188

The public reporting burden for this collection of information is estimated to average 1 hour per response, including the time for reviewing instructions, searching existing data sources, gathering and maintaining the data needed, and completing and reviewing the collection of information. Send comments regarding this burden estimate or any other aspect of this collection of information, including suggestions for reducing the burden, to Department of Defense, Executive Services and Communications Directorate (0704-0188). Respondents should be aware that notwithstanding any other provision of law, no person shall be subject to any penalty for failing to comply with a collection of information if it does not display a currently valid OMB control number.

PLEASE DO NOT RETURN YOUR FORM TO THE ABOVE ORGANIZATION.

1. REPORT DATE (DD-MM-YYYY) June 2006		2. REPORT TYPE Conference paper		3. DATES COVERED (From - To)	
4. TITLE AND SUBTITLE Advanced Wind Technology: New Challenges for a New Century				5a. CONTRACT NUMBER DE-AC36-99-GO10337	
				5b. GRANT NUMBER	
				5c. PROGRAM ELEMENT NUMBER	
6. AUTHOR(S) R. Thresher and A. Laxson				5d. PROJECT NUMBER NREL/CP-500-39537	
				5e. TASK NUMBER WER6.7502	
				5f. WORK UNIT NUMBER	
7. PERFORMING ORGANIZATION NAME(S) AND ADDRESS(ES) National Renewable Energy Laboratory 1617 Cole Blvd. Golden, CO 80401-3393				8. PERFORMING ORGANIZATION REPORT NUMBER NREL/CP-500-39537	
9. SPONSORING/MONITORING AGENCY NAME(S) AND ADDRESS(ES)				10. SPONSOR/MONITOR'S ACRONYM(S) NREL	
				11. SPONSORING/MONITORING AGENCY REPORT NUMBER	
12. DISTRIBUTION AVAILABILITY STATEMENT National Technical Information Service U.S. Department of Commerce 5285 Port Royal Road Springfield, VA 22161					
13. SUPPLEMENTARY NOTES					
14. ABSTRACT (Maximum 200 Words) This paper describes the growth and advances of as well as the challenges faced by the wind energy industry in 2006.					
15. SUBJECT TERMS wind energy; low wind speed technologies; cost of energy;					
16. SECURITY CLASSIFICATION OF:			17. LIMITATION OF ABSTRACT UL	18. NUMBER OF PAGES	19a. NAME OF RESPONSIBLE PERSON
a. REPORT Unclassified	b. ABSTRACT Unclassified	c. THIS PAGE Unclassified			19b. TELEPHONE NUMBER (Include area code)

Standard Form 298 (Rev. 8/98)
Prescribed by ANSI Std. Z39.18